



DANTE Installation Introduction for Windows OS (version 6.3x)

This section describes the installation procedure for DANTE (6.3.x) on Windows OS, including the following components: Package (DANTE FEA and Utility Tools), Plug-In for Abaqus, ACT for Ansys, license installation, a quick install test, and some brief troubleshooting points.

It is recommended to install DANTE after receiving license key(s). DANTE supports floating license for DANTE FEA package, and node-locked license for Utility tools. Admin privileges are required to install and start the floating license.

DANTE Directory and File Structure

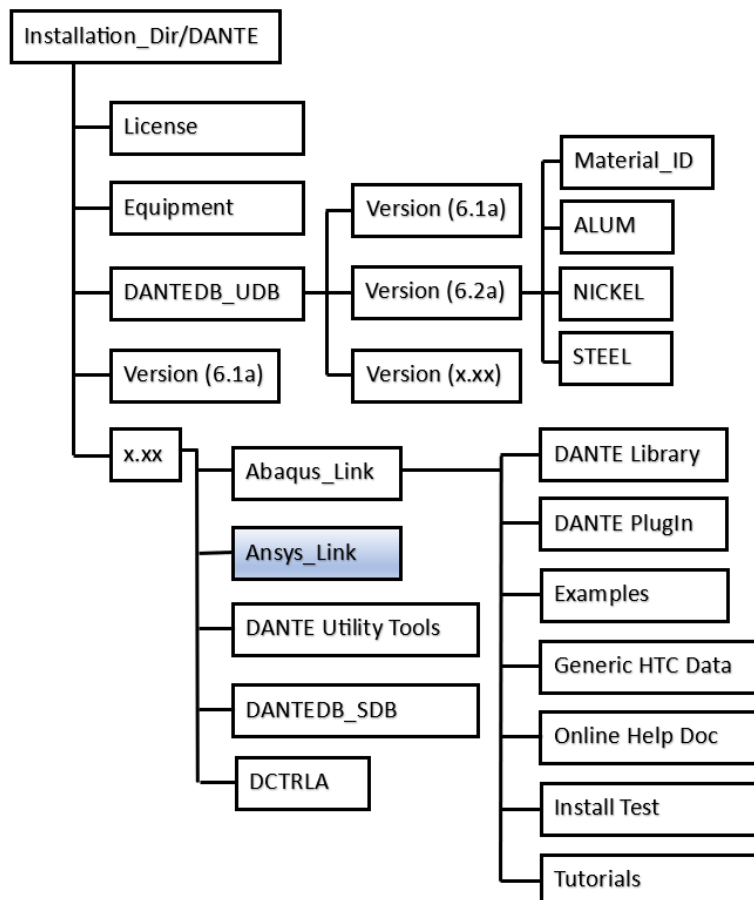

DANTE Installation Wizard for Windows OS

(Admin privileges are required to install under restricted directory or start license server)

Step 1: Double click *DANTE Software Installer File (*.exe)*, select the license setup mode, and follow the installation wizard.

It is recommended to install *DANTE Software* using Admin privileges, so the installed features will be accessible by all users. The “Current user” option supports node-locked license only.

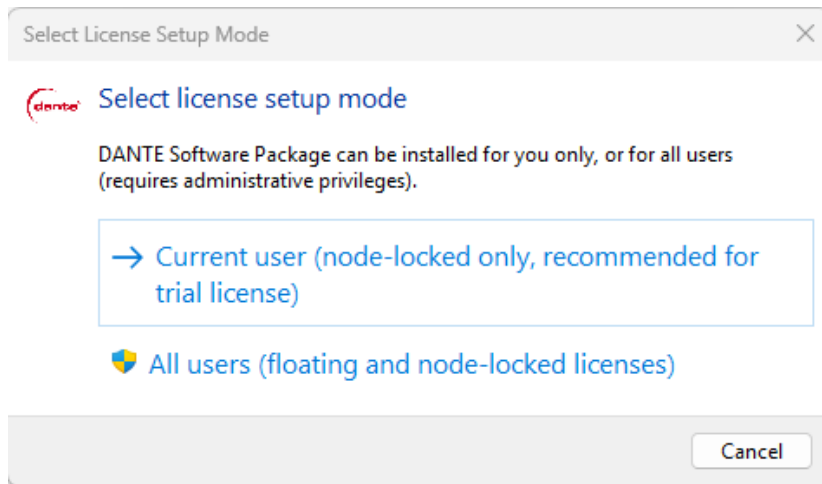

Step 2: Select the installation directory. The default DANTE Software installation directory is:

- *C:\Program Files\DANTE* directory, for installation with Admin privileges (floating and node-locked licenses)
- *C:\Users*user_name*\AppData\Local\Programs\DANTE* directory, for installation by single user without Admin privileges (node-locked license only)
- Note: it is acceptable to install under *c:\DANTE* folder as below.

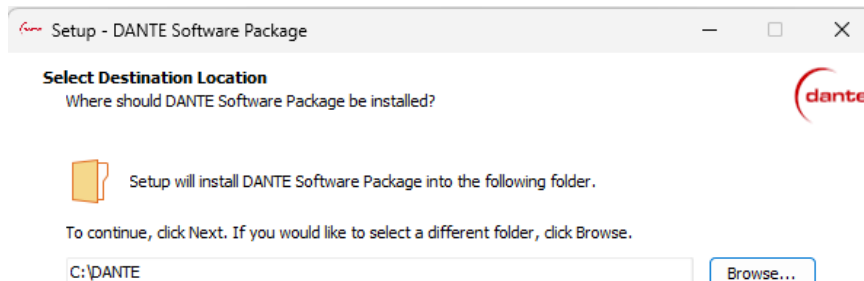

Step 3: Select either “Full installation”, or “Custom installation”. All features can be installed, and the supporting license is required to use any specific features.

Select Components

Which components should be installed?



Select the components you want to install; clear the components you do not want to install. Click Next when you are ready to continue.

Step 4: After installation of the components, the licensing setting will be configured automatically, including the node-locked license and floating license. Select the license files (node-locked, floating, or both) received from DANTE, and the license type (Commercial, Research, or Student/Trial).

Note: **Student/Trial license key** (node-locked) can be downloaded from DANTE website registered user area. Floating license key is not needed for Student/Trial.

Select the License Type.

Step 5: If DANTE FEA feature installation is selected, the specific Ansys (ANS_USER_PATH environment variable) and Abaqus version (usub_lib_dir variable in user folder *abaqus_v6.env* file) can be selected for an automatic configuration.

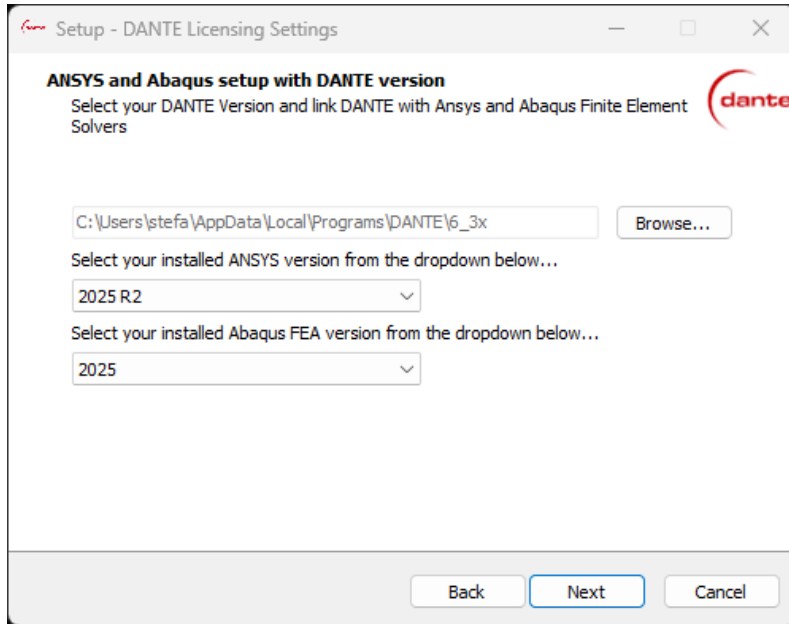

Step 6: After the installation is complete, *Licensing Settings* can be used to customize, reinstall, change the license setting, or configurate with Ansys / Abaqus versions.

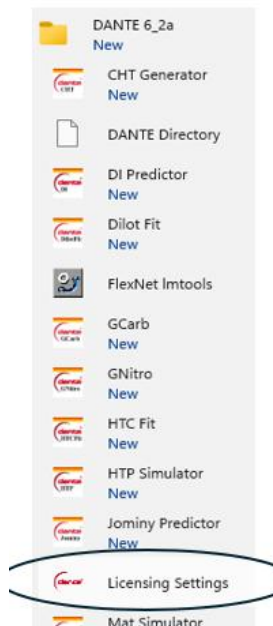

Step 7 (Optional): Run installation test using Abaqus solver (Valid Abaqus/standard and license should be installed).

- Copy the *Install_Test* from DANTE installation directory (\Abaqus_Link\Install_Test) to a working directory.

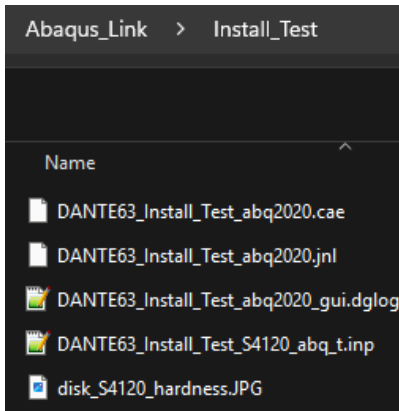

- Run the model using the following command from a *command window* (it is the best to test this under the user's account, not admin's account).

```
abaqus job=DANTE63 Install Test S4120 abq t  
D:\Temp\Install_Test>abq2025 job=DANTE63_Install_Test_S4120_abq_t  
D:\Temp\Install_Test>
```

The generated *.sta file should indicate a successful DANTE installation. (*abaqus* can be replaced by a specific abaqus version (i.e. abq2025) depending on the Abaqus installation and setting)

- (Optional) Abaqus CAE can be started, and the *Dante Model Builder* should show up under “Plug-ins”. (This should be checked from User's account, not admin's account)

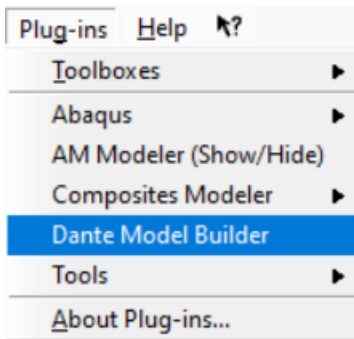

Step 8 (Optional): Run installation test for linking with Ansys.

- Open Ansys Workbench (using the correct Ansys version as specified in the “*ANS_USER_PATH*” variable, which should be configured automatically during installation).
- Set up the DANTE ACT using *Tools → Options → Extensions* and specify the correct installation directory path.

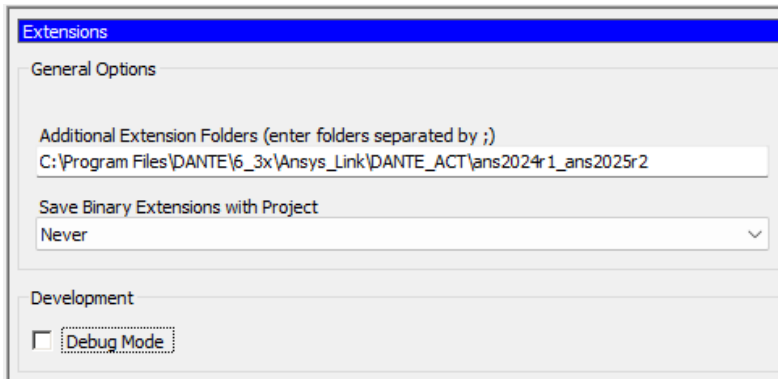

- The *Dante_ACT* (version 6.3) should show up in the Extensions Manager.

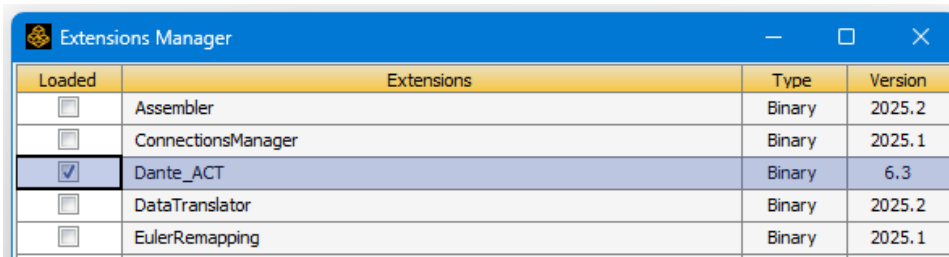

Loaded	Extensions	Type	Version
<input type="checkbox"/>	Assembler	Binary	2025.2
<input type="checkbox"/>	ConnectionsManager	Binary	2025.1
<input checked="" type="checkbox"/>	Dante_ACT	Binary	6.3
<input type="checkbox"/>	DataTranslator	Binary	2025.2
<input type="checkbox"/>	EulerRemapping	Binary	2025.1

- Open the archived Ansys workbench file from DANTE installation directory (\Ansys_Link\Install_Test\)) and save the model to a working directory. The model file was prepared using Ansys 2020R1, and it can be opened with later versions.

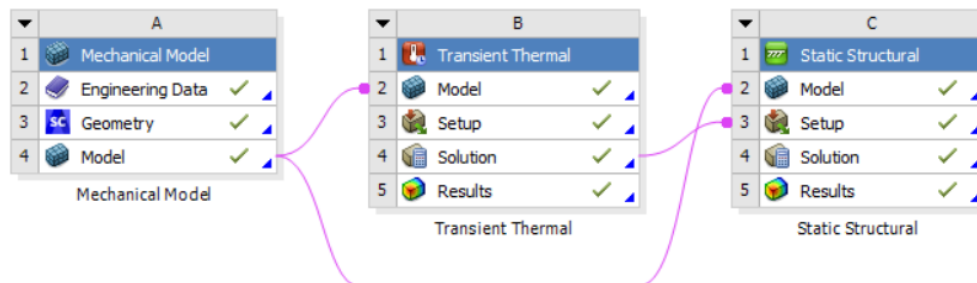

- Open the *Transient Thermal* Model. From DANTE ACT, select “Thermal Model”, Click “Finalize Model Settings”, and run the model.

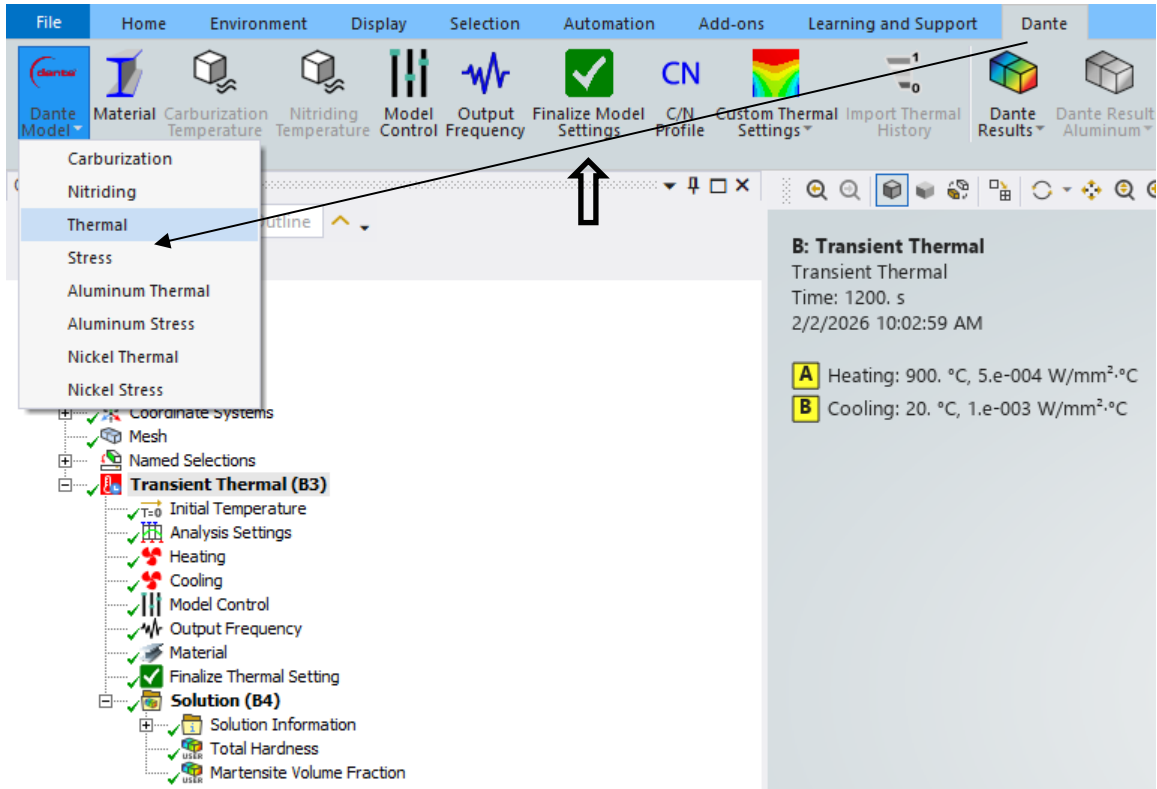

- The results (hardness contour) indicate the installation is successful.

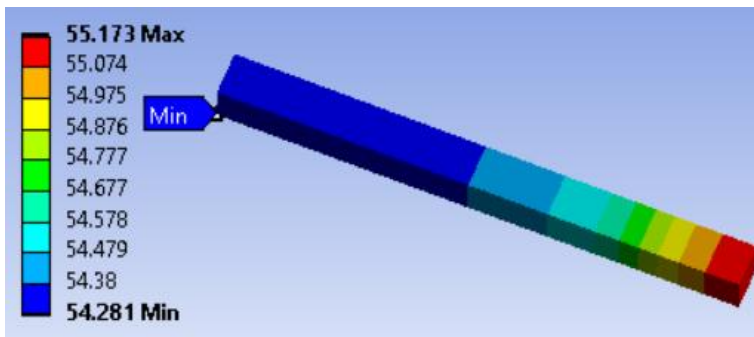

Step 9 (Optional): DANTE Utility Tool run test.

- Open DANTE *TTT_Generator* (or any other licensed tools), load an input file from *examples* folder, and run the model by clicking “*Analyze*” in a working directory (save as to a working directory instead of the installation directory).
- The model results will indicate the installation is successful. (Note: just opening the User Interface doesn’t indicate the installation is successful.)

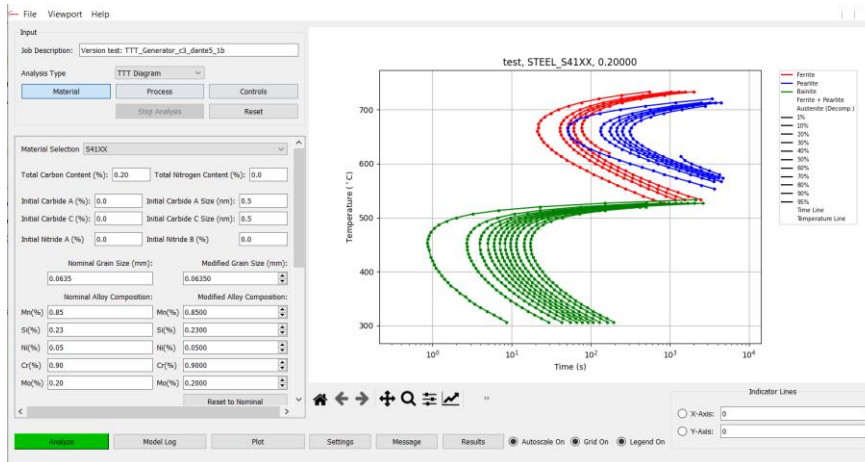

Troubleshooting Points (General)

- Run all models from a working directory instead of the installation directory (The **Program Files** directory may have only limited accessibility to Users) or “C:\” home directory, as these directories may not give permission to edit files.
- For the node-lock license, check the **License.CTL** file from directory “C:\Program Files\DANTE\License”, and make sure the license key is specified correctly after ***LICENSELOC** variable. (“**” in this file is comment line, and it can be ignored.)

```
*LICENSELOC  
C:\Program Files\DANTE\License\dante_license_nl.lic;
```

- The node-locked license doesn’t support remote login. If **remote login** features are required, please contact DANTE Solutions.
- For the floating license, check the **License.CTL** file from directory “C:\Program Files\DANTE\License”, and make sure the license server is specified correctly. The port number (if specified by the server) may be needed when calling license from the server (for example: 27001@server_name;)

```
*LICENSELOC  
@localhost;
```

- For a server hosting DANTE floating license, check whether the server is running.
 - Go to the licensing tools directory (using “cd” command, default c:\Program Files\DANTE\License).
 - Type “**lmdown**” and enter. DANTELM Vendor daemon should show up as Figure below.
 - If “DANTELM” is not shown, then the server is not started yet.

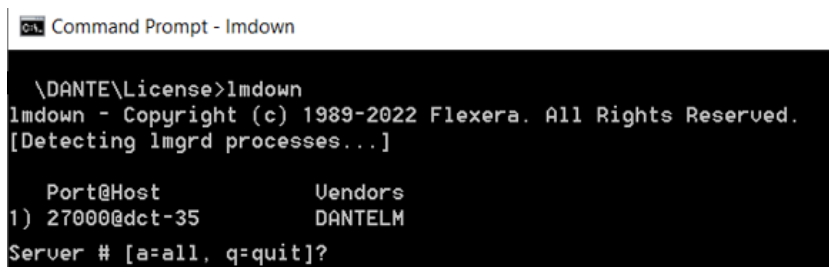

```
Command Prompt - lmdown  
  
\\DANTE\License>lmdown  
lmdown - Copyright (c) 1989-2022 Flexera. All Rights Reserved.  
[Detecting lmgrd processes...]  
  
Port@Host          Vendors  
1) 27000@dct-35     DANTELM  
Server # [a=all, q=quit]?
```

- DANTE **Licensing Settings** from Windows Start can be used to re-install and re-configure the licensing for both node-locked and floating licenses.

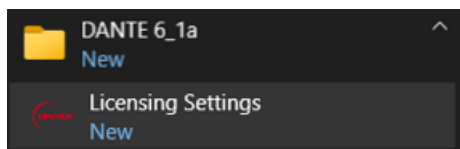

- Command line (**lmgrd -c dante_license_fl.lic -l dante_debug.log**) can be used to start DANTE license server.
 - The command prompt should be opened by “**Run as administrator**”.

Troubleshooting Points (Abaqus only)

- (Abaqus only) Is the *abaqus_v6.env* file in the correct directory? (working directory has the highest priority); check the values for the *usub_lib_dir* and *plugin_central_dir* variables.
- (Abaqus only) For running models on multiple computer nodes, is the *usub_lib_dir* variable setup correctly in *abaqus_v6.env* file providing correct values for all the computer nodes?
- The DANTE installation wizard should have configured the *abaqus_v6.env* file automatically in the specific “*Users*” directory. For a new user, the content of this file can be configured manually or using the “*licensing setting*” for an automatic configuration. The following lines should be added to the *abaqus_v6.env* file.

```
Import os
usub_lib_dir=r'C:\Program
Files\DANTE\6_3x\Abaqus_Link\DANTE_Library\dante6_3x_pr1_windows\abq2025'
os.environ['usub_lib_dir']=usub_lib_dir
plugin_central_dir=r'C:\Program Files\DANTE\6_3x\Abaqus_Link\DANTE_Plugin\abq2024_abq2026'
```

Notes:

- 1) Forward slash or back slash with ‘*r*’ at the beginning of the string should be used to assign string variable values.
- 2) The matching directory (Abaqus version) from DANTE installation should be used for assigning values to *usub_lib_dir* and *plugin_central_dir* variables.
Variable *plugin_central_dir* is used for the DANTE Model Builder Plugin in Abaqus CAE.

Troubleshooting Points (Ansys only)

- (Ansys only) Is **ANS_USER_PATH** system variable setup correctly? Does Ansys version match the DANTE compiled library path? This environment variable is set up automatically during installation. In case of using a different Ansys version, the value of this variable should be adjusted accordingly.
- Units system (**mm, kg, N, s**) should be used.

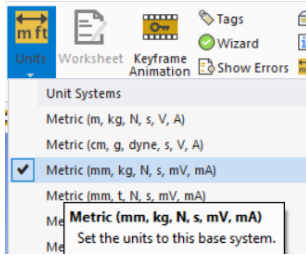

- (Ansys only) the “**Distributed**” under **Home** → **Solve** as shown below should be unchecked unless uncounted DANTE license is granted.

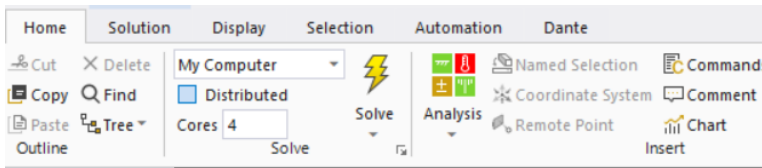

- (Ansys only) Ansys **Enterprise** license is required for the feature of linking with DANTE material models through use subroutines. Note:



- (Ansys only) by clicking “**Finalize Model Setting**”, the **Final Thermal Setting** is added under **Transient Thermal** tree. The “**Commands**” is inserted under Geometry. The material ID should be a positive number, otherwise, the material was not set up correctly.

The screenshot displays the Dante software interface. The top menu bar includes File, Home, Solution, Display, Selection, Automation, and Dante. Below the menu is a toolbar with icons for Dante Model, Material, Carburation Temperature, Nitriding Temperature, Model Control, Output Frequency, Finalize Model Settings (highlighted with a green checkmark), C/N Profile, and Custom Thermal Settings.

The Outline pane on the left shows a project structure:

- Project
- Model (B2)
 - Geometry
 - SYS Solid(Mechanical Model)
 - Coordinate Systems
 - Mesh
 - Named Selections
 - Transient Thermal (B3)
 - Initial Temperature
 - Analysis Settings
 - Heating
 - Cooling
 - Model Control
 - Output Frequency
 - Material
 - Finalize Thermal Setting
- Solution (B4)

A dialog box titled "Finalize Model Settings" is open, showing a green checkmark and the text "Finalize Model Settings".

The code window on the right contains the following text:

```

3 ! The element type numbers for this body can be referenced using the 1-D array parameter "typeids".
4
5 ! Active UNIT system in Workbench when this object was created: Metric (mm, kg, N, s, mV, mA)
6 ! NOTE: Any data that requires units (such as mass) is assumed to be in the consistent solver unit system.
7 ! See Solving Units in the help system for more information.
8
9
10 ! This is material assignment for Thermal model
11
12 *tpele,all,matid
13 *tbdele,all,matid
14 *tb, user, matid, 1, 40
15 *tbdats, 1, 7.8e-09, 0.0, 0.7, 0.0, 0.0, 0.0 11-6: density, modelType, F, P, UB, LB
16 *tbdats, 7, 0.0, 0.0, 0.0, 0.0, 0.004 17-12: M, TM, matID(S41XX). Reserved, Reserved, CRB-ALL,
17 *tbdats, 19, 0.0, 1.0, 0.0, 1.0, 0.0, 0.0 18-19: CRDC, CRDC-SIZE, CRDB, CRDB-SIZE, Reserved, Reserved
18 *tbdats, 15, 0.0, 0.0, 1.0, 0.0, 1.0, 0.0 19-24: N-ALL, NYDA, NYDA-SIZE, NYDS, NYDS-SIZE, Reserved
19 *tbdats, 25, 0.0688, 0.85, 0.23, 0.05, 0.9, 0.2 195-30: GS, Hn, Sl, Ni, Cr, Mo
20 *tbdats, 21, -1.0, -1.0, -1.0, -1.0, 0.0, 0.0 31-36: Cu, V, P, Nb, Al, Ti
21 *tb, state, matid, 190
22 *NP, DEMS, matid, 7.8e-09
23 ! change element type for parts
    
```

Arrows in the image point from the "Coordinate Systems" item in the Outline pane to the "Finalize Model Settings" dialog, and from the "Finalize Model Settings" dialog to the code window. A red circle highlights the value "115" in the code window, with a label "Material ID (positive integer)" pointing to it.

How to Obtain MAC Address of user's computer and server?

MAC address of the user's computer or server is required by DANTE to generate the license key. The following command can be used to obtain the MAC address:

- Run command `ipconfig -all > computer_info.txt` from a command window. The generated file `computer_info.txt` contains the MAC address information.

```
Command Prompt
Microsoft Windows [Version 6.1.7601]
Copyright (c) 2009 Microsoft Corporation. All rights reserved.

C:\Users\admin>ipconfig -all > computer_info.txt
```

- Run `lmhostid` (FlexNet tool) from a command window (Note: this tool is available in the DANTE License directory)

```
Command Prompt

C:\DANTE\License>lmhostid.exe
lmhostid - Copyright (c) 1989-2022 Flexera. All Rights Reserved.
The FlexNet host ID of this machine is ""20111111111111111111111111111111""
Only use ONE from the list of hostids.
```

- Run `FlexNet lmtools` from DANTE start. The MAC address shows under system setting.

